

EVERYTHING YOU NEED FROM THE DECK UP

DF-356 FASST WINDER WINCH Features & Specifications

- Hot-dipped Galvanized coating.
- Patented high load release dog with secondary anti-backlash drag brake that is activated automatically with the release of the dog.
- High load release brake is a multi-disc system that incorporates all stainless steel moving parts.
- No hot work required: mounts to DF-3, DF-156 and some competitors models.
- Heaviest winch in its class at 1,650 lbs.
- Incorporates our powerful FASST Winder system.
- No ratchet or ratchet handle extension.
- Ergonomic height.
- Uses standard 40-ton winch drive train.

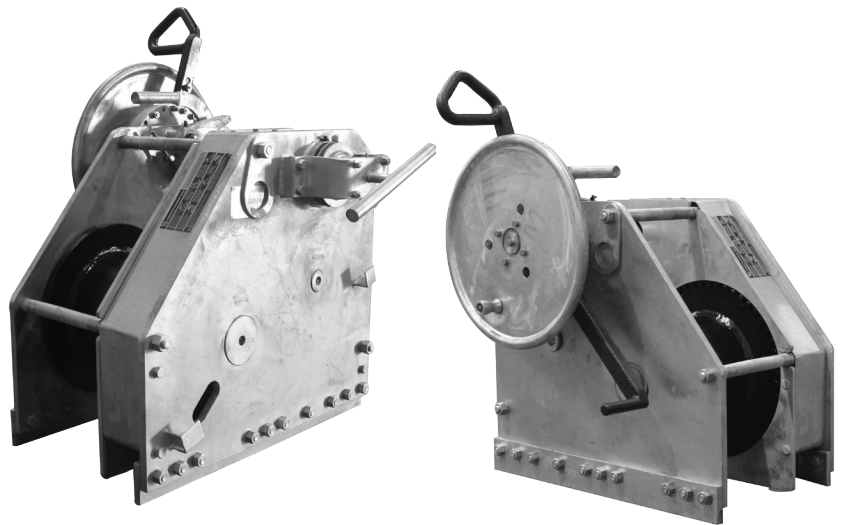

- 2 year warranty.
- Fully guarded gears.
- Fastest and easiest way to fully tighten a winch.

MODEL NO.	HOLDING DOG & OR BRAKE	LINE PULL @ FIRST LAYER WITH ONE MAN (LBS)		DRUM CAPACITIES (FT)					WEIGHT
		HAND WHEEL	RATCHET W/STD. EXT.	5/8"	3/4"	7/8"	1"	1-1/8"	
DF-356-UFW	S. TONS								LBS
40-11-M	40	8,000	17,800	340	219	132	115	60	1,650
40-18-M	40	8,000	17,800	563	363	224	198	107	1,875



NABRICO

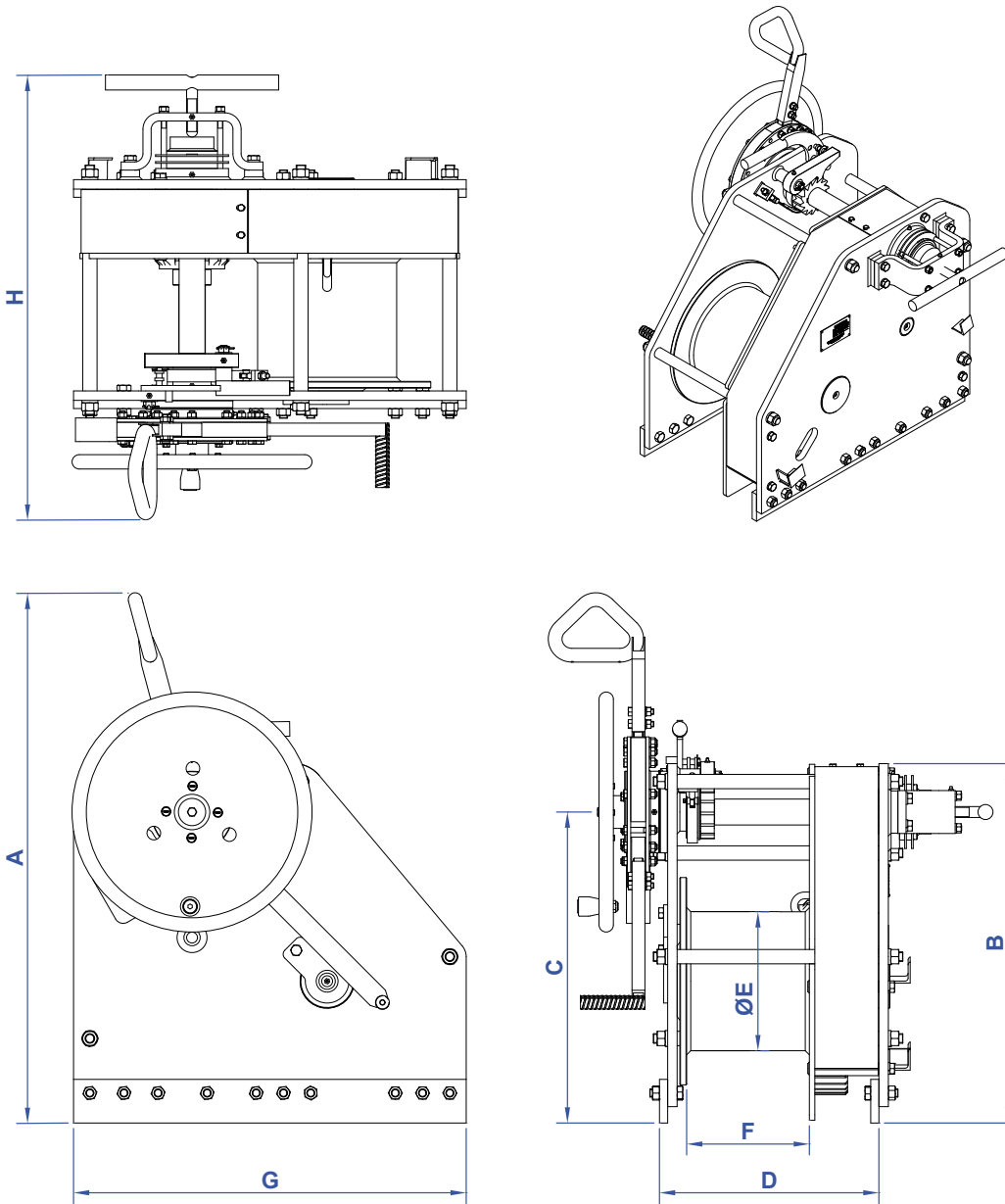

MODEL NO.	A	B	C	D	ØE	F	G	H
40-11	48-9/16"	33"	28-1/2"	20-1/8"	12-3/4"	11-1/4"	36"	40-3/4"
40-18	48-9/16"	33"	28-1/2"	26-1/4"	12-3/4"	18-1/8"	36"	46-7/8"