

**THE RIGHT CHOICE WHEN YOU NEED TO**

**POWER UP**

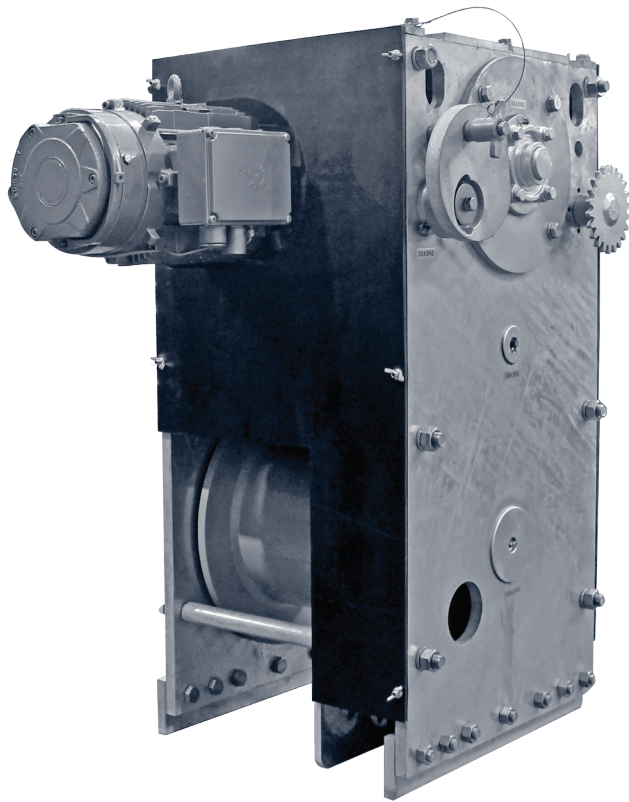

## **DF-1 N ELECTRIC WINCH**

### **Features & Specifications**

- Salt water package standard on all power winches.
- Hot-dipped galvanized.
- Stainless or silicon bronze fasteners.
- 3-ply conveyer belt covers (damage and corrosion resistant).
- 3-tooth locking dog with large release and fail-safe disc brake.
- NEMA motor design with helical-bevel gearbox.
- Heaviest winch in its class.
- Variable frequency drive option available. Amp draw limits, variable speeds, and motor protection.
- Made as one model adjustable to true right or left hand models for use in pairs.
- Over 100 fewer parts than other electric winches (no chain or sprockets).
- 30 Ton - 5 HP motor standard.
- 40 Ton - 7.5 HP motor standard.
- 65 Ton - 10 HP motor standard.

MODEL	HOLDING DOG & OR BRAKE	LINE PULL		LINE SPEED 1ST LAYER (FPM)	DRUM CAPACITIES (FT)				WEIGHT (LBS)
		@ RATED AMPS	@ MOTOR STALL		1/2"	5/8"	3/4"	1"	
DF-I-30	30 TONS	7,495	23,234	21	361	228	138	66	1700
DF-I-40	40 TONS	10,140	30,420	23	-	287	180	100	1800
DF-I-65	65 TONS	24,310	77,791	13	-	572	325	200	3200



**NABRICO**



**Right Hand Winch Shown  
Left Hand Winch Opposite**

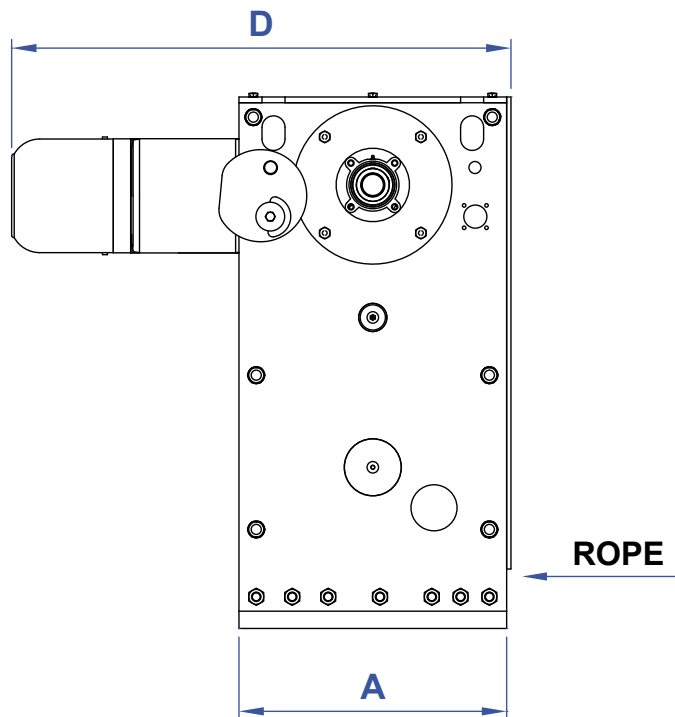
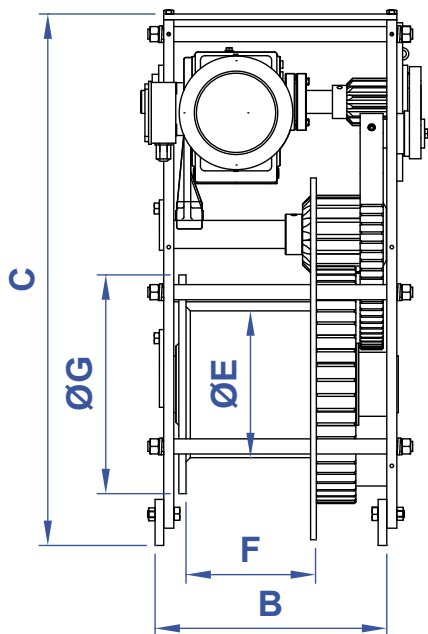
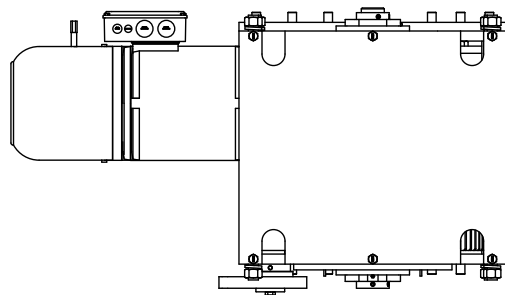

MODEL	A	B	C	D	ØE	F	ØG
DF-I-30	22"	19-3/8"	39"	36"	10-3/4"	11-1/4"	16"
DF-I-40	23-1/4"	20-1/8"	46-1/8"	43-3/8"	12-3/4"	11-1/4"	19"
DF-I-65	30"	23-1/8"	55-1/2"	45-5/8"	14"	10-5/8"	24"